

1 2 3 4 5 6 7 8 9

F

F

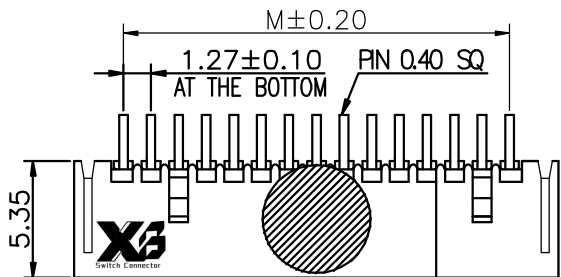

Recommended P.C.Board Layout
(Tolerance:±0.05)

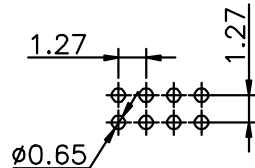

Specifications
 Current Rating:1.0Amp
 Insulation Resistance:1000MΩMin.
 Dielectric Withstanding Voltage:300VAC
 Contact Resistance:20mΩMax.
 Operating Temperature:-40°C to +105°C
 Materials
 Contact Material:Phosphor Bronze
 Insulator Material:High Temperature Thermoplastic, UL 94V-0 LCP or the equivalent material
 All materials must meet XI BANG hazardous substances control standards.

E

E

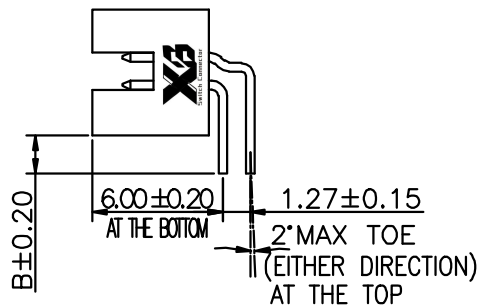
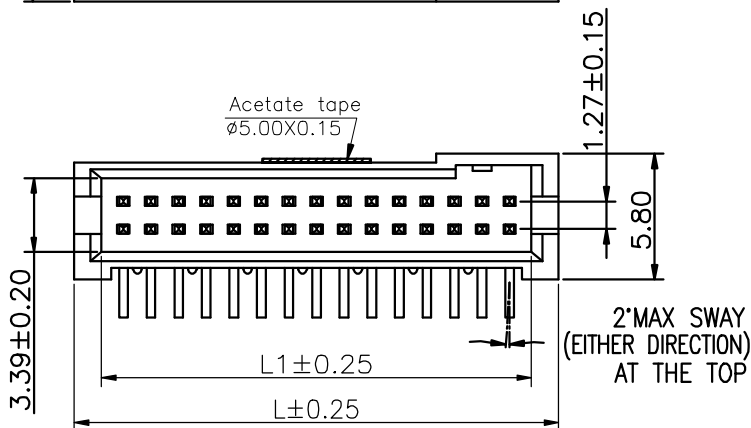

D

D

C

C

Ordering Information

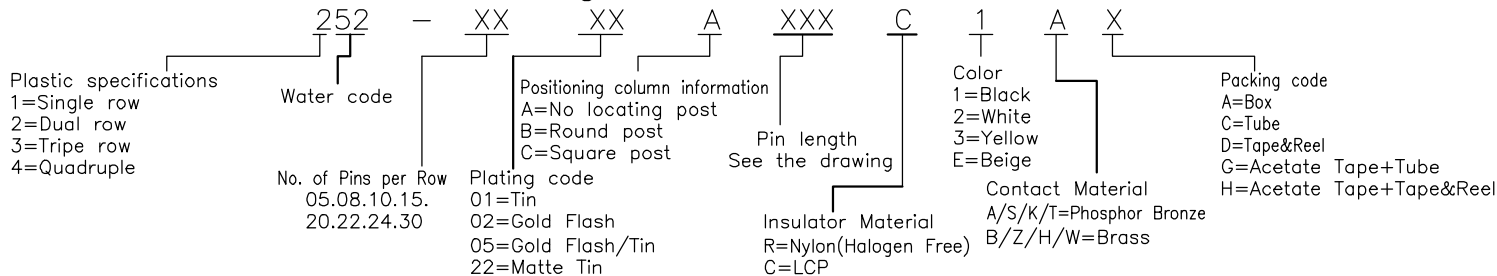

No. of PIN/ROW	Dimension Information		
	M	L1	L
05	5.08	7.10	9.60
08	8.89	10.91	13.41
10	11.43	13.45	15.95
15	17.78	19.80	22.30
20	24.13	26.15	28.65
22	26.67	28.69	31.19
24	24.00	29.21	33.68
30	36.83	38.85	41.35

A

A

东莞市溪榜电子有限公司 DONG GUAN XI BANG ELECTRONICS CO., LTD	GENERAL TOLERANCE		DESIGNED:	DATE:	DWG. NO.	TITLE: 1.27 BOX HEADER DUAL ROWS R/A TYPE CONNECTOR
	X'±5.0'	X±0.30	CHECKED:	DATE:		
	.X'±3.0'	.X±0.25	CO SIGNED:	DATE:	PART NO.	
	.XX'±2.0'	.XX±0.15	APPROVED:	DATE:		
REV. 01	UNIT. mm	SCALE. 3:1	PAGE. 1/1			

1 2 3 4 5 6 7 8 9