

1 2 3 4 5 6 7 8 9

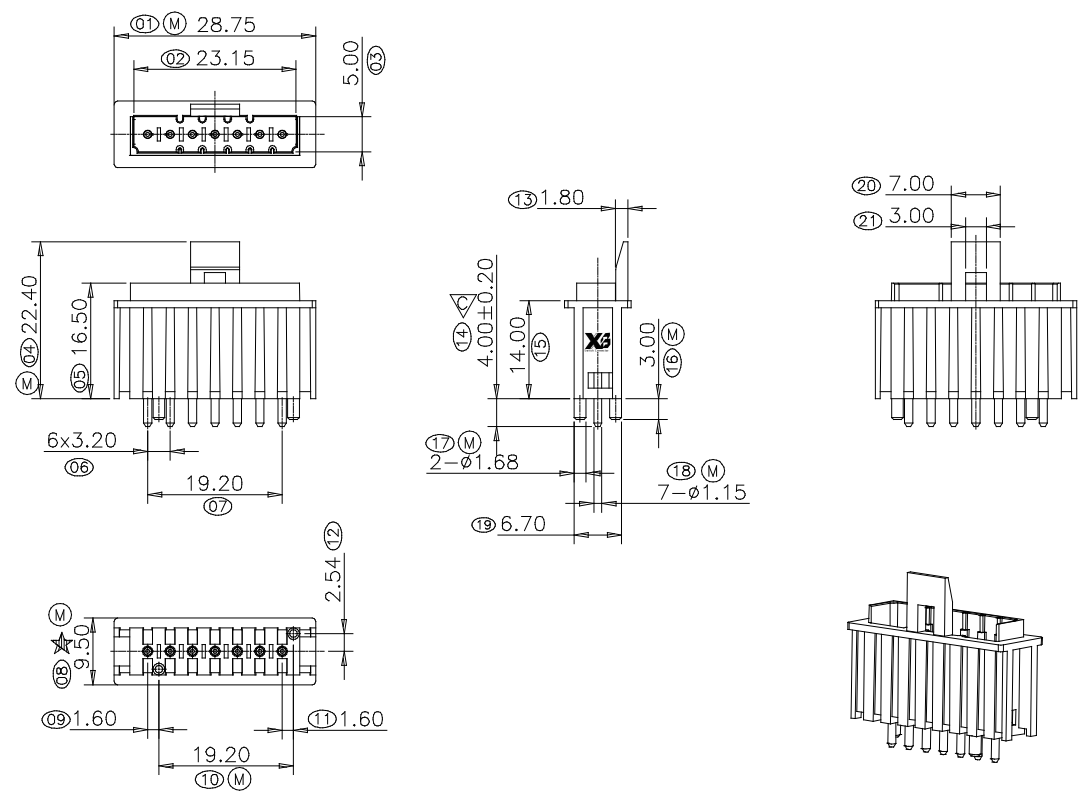

Specifications  
 Current Rating:1Amp  
 Insulation Resistance:100MΩMin.  
 Dielectric Withstanding Voltage:600VAC  
 Contact Resistance:20mΩMax.  
 Operating Temperature:-40°C to +105°C  
 Materials  
 Contact Material:Copper alloy  
 Regular Thermoplastic: Only Suitable for Wave Soldering Process (PBT).  
 ☆ All materials must meet XI BANG hazardous substances control standards.  
 "☆": Critical Characteristics, indicates product characteristics, functionalities, and manufacturing processes regarding to customer's specifications  
 "☆": Safety Features indicates product characteristics, functionalities, and manufacturing processes complying to legal regulations stated by local government

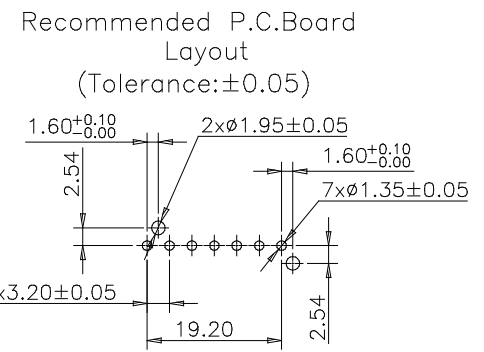

### Ordering Information

XB-CAR-119 - XX XX B 001 X X X X

No. of Pins per Row 07  
 Standard Plating 01=Tin  
 Insulator Material K=PBT (Halogen Free)  
 Color 1=Black 5=Natural  
 Contact Material B=Brass  
 Standard Packing C=Tube Selective Packing A=Box

东莞市溪榜电子有限公司 DONG GUAN XI BANG ELECTRONICS CO., LTD	3RD.ANG PROJ.	GENERAL TOLERANCE		DESIGNED:	DATE:	DWG. NO. XB-CAR-119	TITLE. 3.20 PIN HEADER SINGLE ROW DIP TYPE CONNECTOR
	3RD.ANG PROJ.	X.*±5.0°	X.±0.35	CHECKED:	DATE:		
REV. A	UNIT. mm	SCALE. 1:1	PAGE. 1/1	.X*±3.0°	.X±0.35	PART NO.	
				.XX*±2.0°	.XX±0.30		
				.XXX*±1.0°	.XXX±0.20		

1 2 3 4 5 6 7