

Specifications
 Current Rating:3.0Amp
 Insulation Resistance:1000MΩMin.
 Dielectric Withstanding Voltage:600VAC
 Contact Resistance:20mΩMax.
 Operating Temperature:-40°C to +105°C
 Materials
 Contact Material:
 Brass(Pin length less than 25mm)
 Phosphor Bronze(The total length of pin is more than 25mm)
 Insulator Material:
 Nylon(High temperature resistance),
 LCP(High temperature resistance),
 UL 94V-0
 All materials must meet XI BANG hazardous substances control standards.

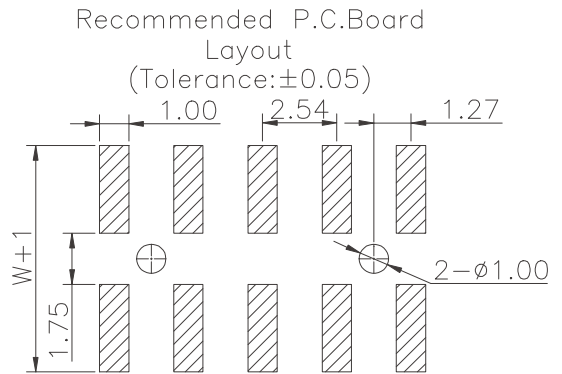
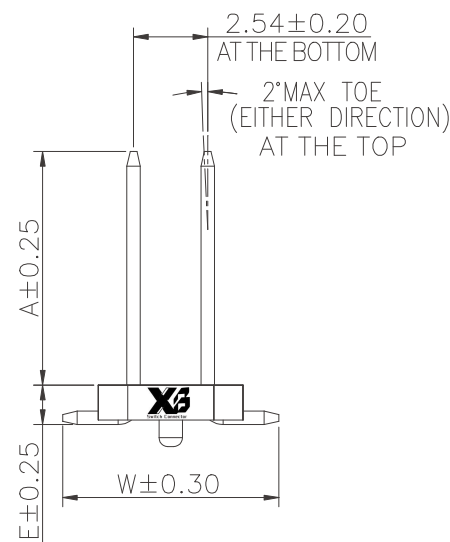
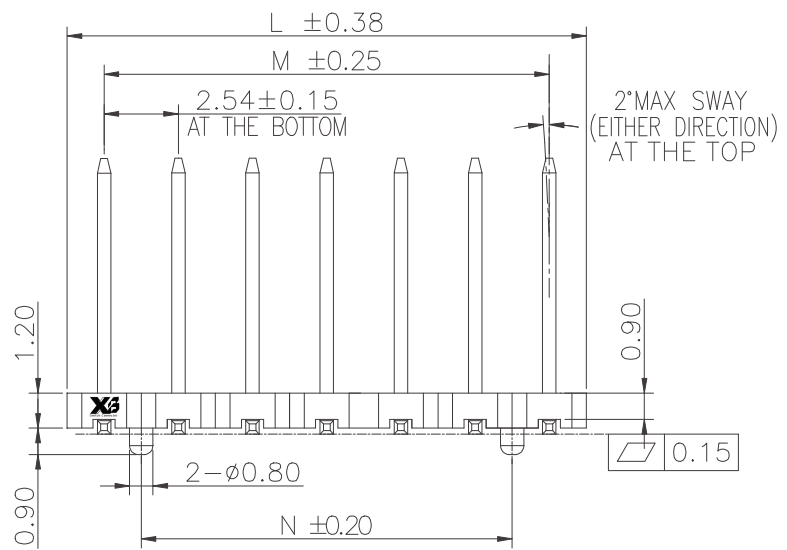

Ordering Information

213 - XX XX B XXX X 1 X X

Plastic specifications
 1=Single row
 2=Dual row
 3=Tripe row
 4=Quadruple

Water code

No. of Pins per Row
 02~09

Positioning column information
 A=No locating post
 B=Round post
 C=Square post

Plating code
 01=Tin
 02=Gold Flash
 05=Gold Flash/Tin
 22=Matte Tin

Pin length
 See the drawing

Insulator Material
 R=Nylon(Halogen Free)
 C=LCP

Color
 1=Black
 2=White
 3=Yellow
 E=Beige

Contact Material
 A/S/K/T=Phosphor Bronze
 B/Z/H/W=Brass

Packing code
 A=Box
 B=Tray
 C=Tube
 D=Tape&Reel
 E=Cap+Tube
 F=Cap+Tape&Reel
 G=Acetate Tape+Tube
 H=Acetate Tape+Tape&Reel

No. of PIN/ROW	Dimension Information		
	M	L	N
02	2.54	5.08	VIEW-1
03	5.08	7.62	VIEW-2
04	7.62	10.16	5.08
05	10.16	12.70	7.62
06	12.70	15.24	10.16
07	15.24	17.78	12.70
08	17.78	20.32	15.24
09	20.32	22.86	17.78

XIB 东莞市溪榜电子有限公司
 DONG GUAN XI BANG ELECTRONI CS CO., LTD.

GENERAL TOLERANCE	
.X°±5.0°	.X±0.30
.X°±3.0°	.X±0.25
.XX°±2.0°	.XX±0.15
.XXX°±1.0°	.XXX±0.10

DWG. NO. XB-PZ-C-254-213
 PART NO.

TITLE.
 2.54mm PIN HEADER
 DUAL ROW WITH POST
 S.M.T TYPE

REV.	UNIT.	SCALE.	PAGE.
01	mm	4:1	1/1