

Specifications
 Current Rating:1.0Amp
 Insulation Resistance:1000MΩMin.
 Dielectric Withstanding Voltage:300VAC
 Contact Resistance:20mΩMax.
 Operating Temperature:-40°C to +105°C
 Materials
 Contact Material:Phosphor Bronze
 Insulator Material:High Temperature Thermoplastic, UL 94V-0 LCP or the equivalent material
 All materials must meet XI BANG hazardous substances control standards.

Recommended P.C.Board Layout

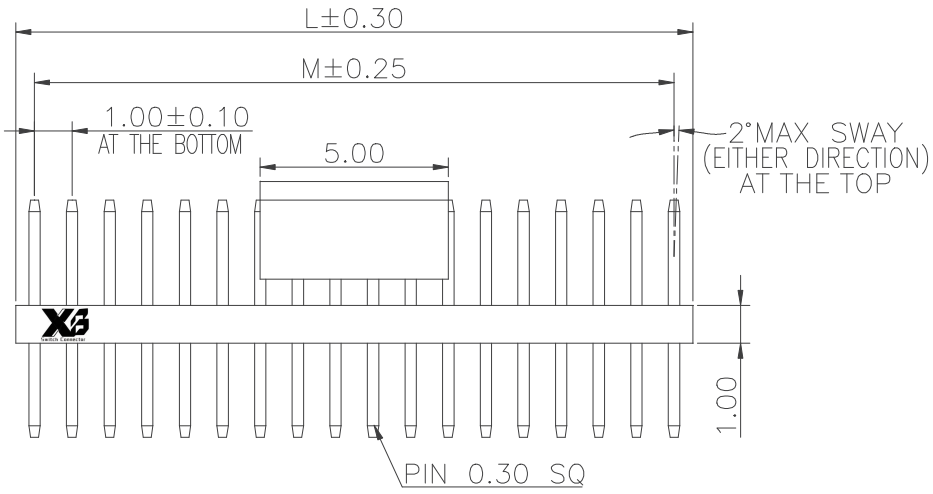
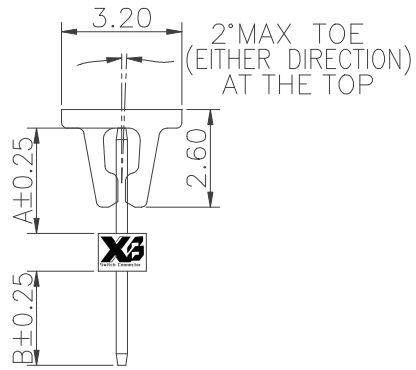
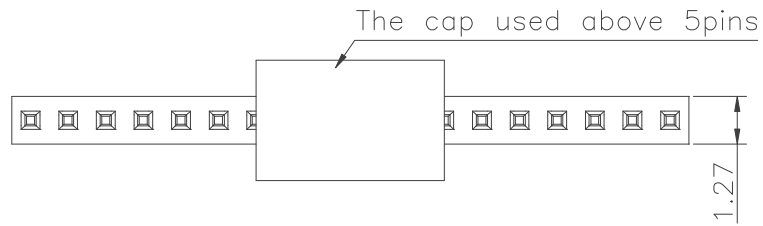
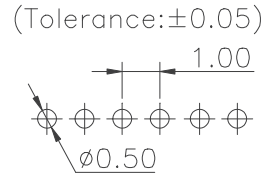

No. of PIN/ROW	Dimension Information	
	M	L
02	1.00	2.00
03	2.00	3.00
04	3.00	4.00
05	4.00	5.00
06	5.00	6.00
07	6.00	7.00
08	7.00	8.00
09	8.00	9.00
10	9.00	10.00
11	10.00	11.00
12	11.00	12.00
13	12.00	13.00
14	13.00	14.00
15	14.00	15.00
16	15.00	16.00
17	16.00	17.00
18	17.00	18.00
19	18.00	19.00
20	19.00	20.00
21	20.00	21.00
22	21.00	22.00
23	22.00	23.00
24	23.00	24.00
25	24.00	25.00
26	25.00	26.00
27	26.00	27.00
28	27.00	28.00
29	28.00	29.00
30	29.00	30.00
31	30.00	31.00
32	31.00	32.00
33	32.00	33.00
34	33.00	34.00
35	34.00	35.00
36	35.00	36.00
37	36.00	37.00
38	37.00	38.00
39	38.00	39.00
40	39.00	40.00

Ordering Information

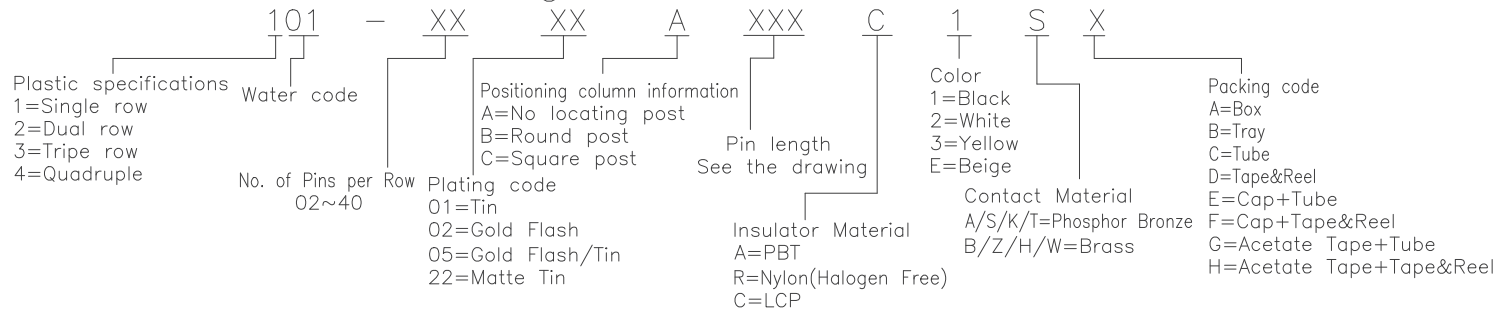

X3 东莞市溪榜电子有限公司
 Switch Connector DONG GUAN XI BANG ELECTRONICS CO., LTD.

GENERAL TOLERANCE	
X.*±5.0°	X.±0.30
.X*±3.0°	.X±0.25
.XX*±2.0°	.XX±0.15
.XXX*±1.0°	.XXX±0.10

DWG. NO.
XB-PZ-A-10-101
 PART NO.

TITLE.
 1.00 PIN HEADER
 SINGLE ROW DIP TYPE
 CONNECTOR

REV.	UNIT.	SCALE.	PAGE.
01	mm	5:1	1/1