

Recommended P.C.Board
Layout
(Tolerance:±0.05)

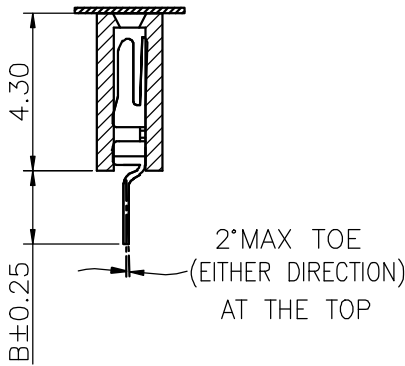
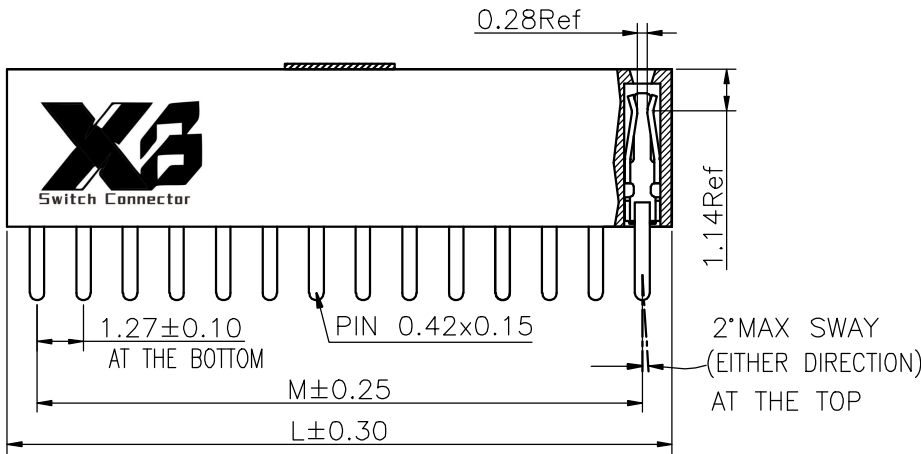
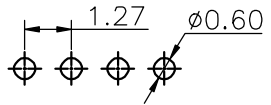

Specifications
Current Rating:1Amp
Insulation Resistance:1000MΩMin.
Dielectric Withstanding Voltage:300VAC
Contact Resistance:20mΩMax.
Operating Temperature:-40°C to +105°C
Materials
Contact Material:Phosphor Bronze
Insulator Material:High Temperature Thermoplastic, UL 94V-0 LCP or the equivalent material
All materials must meet XI BANG requirement for environment protection.

No. of PIN/ROW	Dimension Information	
	A	B
02	1.27	2.89
03	2.54	4.16
04	3.81	5.43
05	5.08	6.70
06	6.35	7.97
07	7.62	9.24
08	8.89	10.51
09	10.16	11.78
10	11.43	13.05
11	12.70	14.32
12	13.97	15.59
13	15.24	16.86
14	16.51	18.13
15	17.78	19.40
16	19.05	20.67
17	20.32	21.94
18	21.59	23.21
19	22.86	24.48
20	24.13	25.75
21	25.40	27.02
22	26.67	28.29
23	27.94	29.56
24	29.21	30.83
25	30.48	32.10
26	31.75	33.37
27	33.02	34.64
28	34.29	35.91
29	35.56	37.18
30	36.83	38.45
31	38.10	39.72
32	39.37	40.99
33	40.64	42.26
34	41.91	43.53
35	43.18	44.80
36	44.45	46.07
37	45.72	47.34
38	46.99	48.61
39	48.26	49.88
40	49.53	51.15

Ordering Information

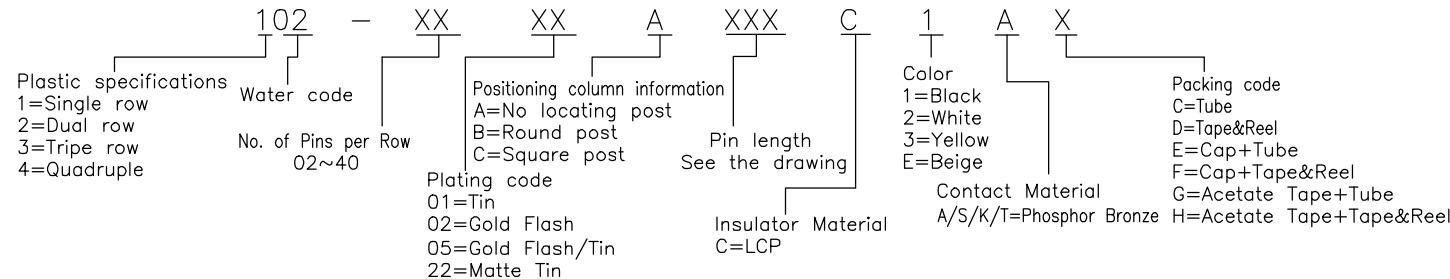

XB 东莞市溪榜电子有限公司
DONG GUAN XI BANG ELECTRONICS CO., LTD.

GENERAL TOLERANCE	
X.'±5.0'	X.±0.30
.X'±3.0'	.X±0.25
.XX'±2.0'	.XX±0.15
.XXX'±1.0'	.XXX±0.10

DESIGN:	DATE:
CHECKED:	DATE:
AUDITED:	DATE:
APPROVED:	DATE:

DWG. NO.	XB-PM-A-127-102
PART NO.	

TITLE:
1.27 FEMALE HEADER
SINGLE ROW DIP TYPE

REV. 01	UNIT. mm	SCALE. 3:1	PAGE. 1/1	
---------	----------	------------	-----------	--