

CAD FILE:

**ROHS**

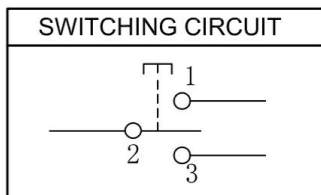
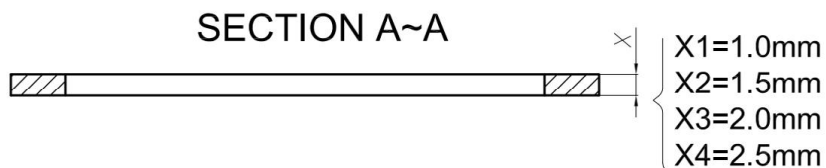
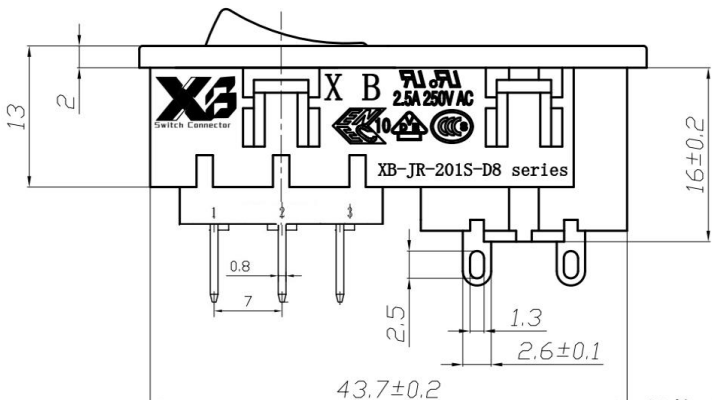
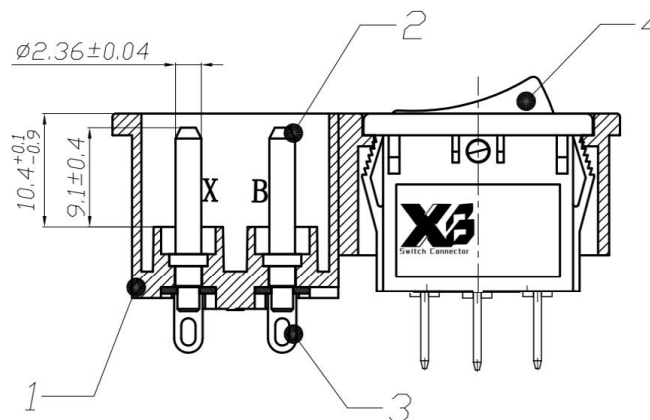
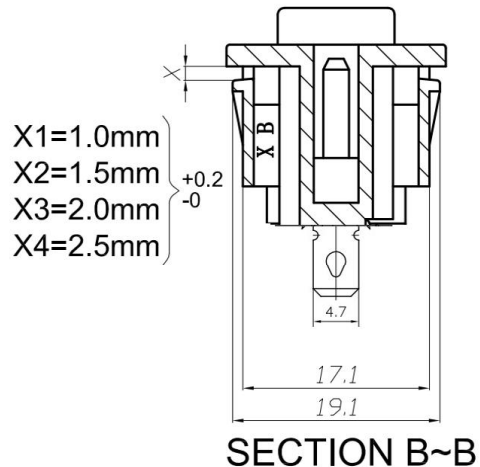
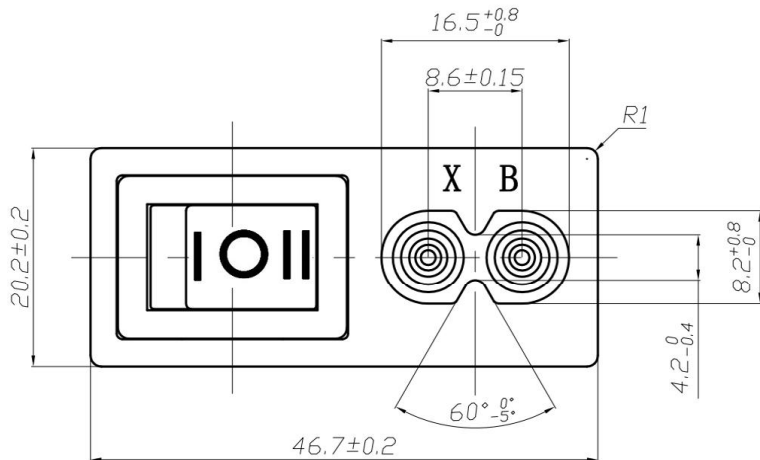

规格 SPECIFICATION

1. 额定值 RATING: 2.5A 250VAC
2. 绝缘电阻 INSULATION RESISTANCE:  $\geq 100M\Omega$  (DC500V/1MIN)
3. 介电强度 DIELECTRIC STRENGTH: 2000V /0.5mA /1MIN
4. 工作温度 OPERATING TEMPERATURE: -25°C TO +85°C (MAX)
5. 端子浸焊条件 DIP SOLDERING: 265°C, 3S



编号	零件名称	数量	材质说明
1	Body	1	PA
2	Pin	2	Brass Alloy, Ni-Plated
3	Terminal	2	Brass Alloy, Tin-Plated
4	Switches	1	Double Pole

NO.	PARTS	MATERIALS	Q'TY	FINISH	TOLERANCE UNLESS SPECIFIED	DATE	REV	DESCRIPTIONS OF REVISION	APPD.
8									
7									
6					WITHIN 1.5mm : $\pm 0.1mm$	A	2012-9-25	初版	ZENQ. CHEN
5					OVER 1.5mm : $\pm 0.2mm$	ISSUE	DATE	DESCRIPTIONS OF REVISION	APPD.
4	CONTACT	SUS	1	Ag CLAD	TITLE : AC POWER SOKET		UNIT : mm	DRWG NO.: XB-JR-201S-D8-3P-3T	
3	CASE	PPA/BRASS SRTIP	1	BLACK/Ag PLATED	MODEL: XB-JR-201S-D8-3P-3T		SCALE: 5:1	DWN. JUN. YANG	2012-9-25
2	COVER	STEEL STRIP	1	Ni PLATED	东莞市溪榜电子有限公司		CHK'D DONG. PANG	2012-9-25	
1	KNOB	PPA	1	BLACK	DONG GUAN XI BANG ELECTRONI CS CO., LTD.		APPD. ZENQ. CHEN	2012-9-25	