



标准&定制开关连接器产品制造商
DONG GUAN XI BANG ELECTRONICS CO., LTD.

规格书

SPECIFICATION

CUSTOMER NAME 客户名称: _____
 CUSTOMER NO. 客户编号: _____
 SERIES 系列: XB-DCD电动车充电座
 MODEL NO. 型号: XB-M19-2+3菱形母座
 DRAWING NO. 图形号: Electric vehicle charging seat

If specification of this product meets your request, please confirm all the items of it and return to us with signature and stamp, it will be basis of our production and record. Thanks your cooperation in advance!

若此产品规格符合贵司要求，敬请确认此规格书内所有项目
 并签名和盖章后回传给我司，以作我司产品制作之
 依据和存档之用，多谢合作！

EXAMINE & APPROVAL 审批

APPROVE 接受	NOT APPROVE 不接受
SIGNATURE 签署 STAMP 盖章 DATE 日期	

PREPARED BY. 制表人	CHECKED BY. 校对	APPROVED BY. 审核	APPROVAL BY. 批准
<div style="border: 1px solid red; padding: 2px;">研发部</div> <div style="border: 1px solid red; padding: 2px;">戴海明</div> <div style="border: 1px solid red; padding: 2px;">2022. 06. 08</div>	<div style="border: 1px solid red; padding: 2px;">品质部</div> <div style="border: 1px solid red; padding: 2px;">黄自清</div> <div style="border: 1px solid red; padding: 2px;">2022. 06. 08</div>	<div style="border: 1px solid red; padding: 2px;">工程部</div> <div style="border: 1px solid red; padding: 2px;">庞军</div> <div style="border: 1px solid red; padding: 2px;">2022. 06. 08</div>	<div style="border: 1px solid red; padding: 2px;">总经办</div> <div style="border: 1px solid red; padding: 2px;">吴量</div> <div style="border: 1px solid red; padding: 2px;">2022. 06. 08</div>

东莞市溪榜电子有限公司

Dong guan Xi Bang Electronics Co., Ltd
 地址: 广东省东莞市黄江镇合路工业区
 Address: He Lu Industrial Zone, Huangjiang Town
 , Dongguan City, Guangdong Province
 Tel: (0769)82055138/82056828
 Fax: (0769)83663452

邮箱: admin@alspr.com switch@alspr.com
<http://www.alspr.cn/> <http://www.alspr.com/>

Dong Guan XB Electronics Co., Ltd

AccountNumber: 705540238
 BankName: Citibank N. A., HongKongBranch
 Country/Region: Hong Kong
 BankCode: 006
 BankAddress: 3GardenRoad, Central, Hong Kong
 SWIFT/BIC: CITIHKHX (CITIHKHXXXX*If11charactersare
 required)

MAil: HK@ALPSR.CN XB@ALPSR.CN XB@ALPSR.COM
 Quality core! Afterburner for Made in China!



东莞市溪榜电子有限公司

DONG GUAN XI BANG ELECTRONICS CO., LTD

承认书目录

1	封面	-----	1
2	目录	-----	2
3	包装规范	-----	3
4	零件图	-----	4
5	出货检验报 FAI	-----	5
6	规格参数	-----	6-10
7	性能检测	-----	11-12



东莞市溪榜电子有限公司

DONG GUAN XI BANG ELECTRONICS CO., LTD

包装规格书

品名	XB-M19/2+3充电母座
型号:	
料号:	



产品图示

XB-M19菱形母座2+3



1内盒=100PCS

22.5CM*19CM*6.3CM纸盒



1外箱=24盒

47CM*39.5CM*40CM外箱

一盒=100 PCS
 一箱=24 盒
 一箱=100PCS*10盒=2400 PCS
 外箱外形尺寸：47*39.5*40CM
 (M23母座成品)净重：12KG
 (M23母座成品)毛重：13.2KG



日期	制作	审核	批准	版次
2023/4/16	庞东	杨军	吴量	A0

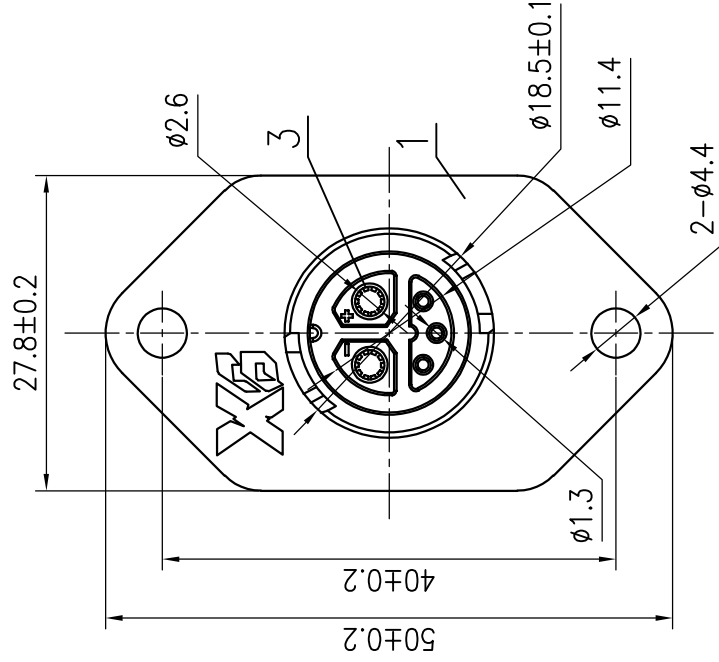
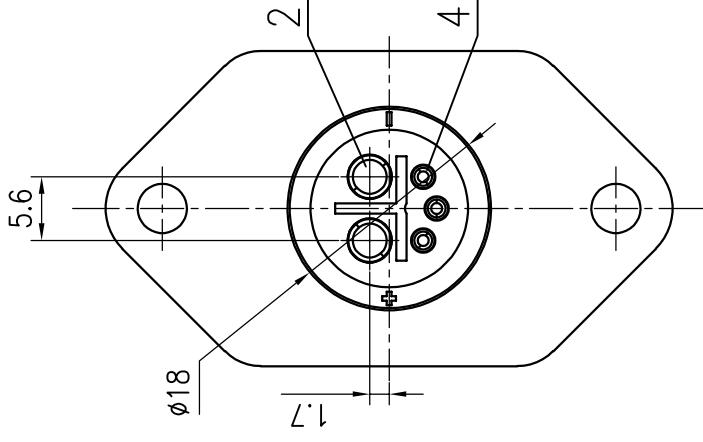
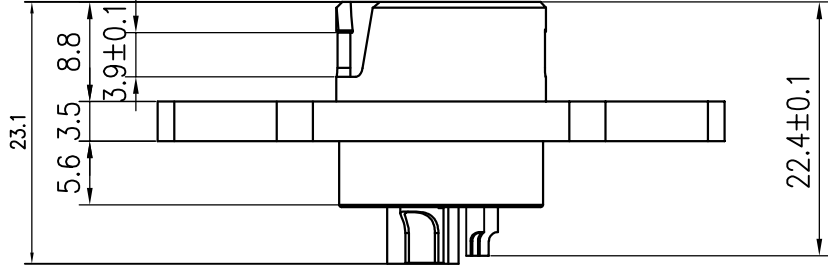

- 主要技术特性要求:
1. 与插头对插手感无卡顿
 2. 插簧保持力 $\geq 70\text{N}$, 小插簧 $\geq 20\text{N}$.
 3. 插拔力: 成品 $15\sim 50\text{N}$,
插簧单Pin插拔力 $3\sim 8\text{N}$,
小插簧单Pin插拔力 $2\sim 4\text{N}$.
 4. 接触电阻: $10\text{m}\Omega$ Max.

4	小插簧	黄铜HPb59-1	3	镀金 1μ	
3	冠簧	钛青铜	2	镀金 1μ	
2	插簧	黄铜HPb59-1	2	镀金 1μ	
1	底座	PA66, UL94 V-0	1	黑色	
序号	零件料号	名称	材料	数量	镀层/颜色

XB 东莞市溪榜电子有限公司
DONG GUAN XI BANG ELECTRONIC CS CO., LTD.

设计	JUN. PANG	日期	2020-8-10	产品型号	XB-M19-2+3-D2	
审核	LIANG. WU	日期		产品料号		
批准	ZENQ. CHEN	日期		页码	1 OF 1	A4
比例		单位	mm			
M19菱形母座 2+3(基础版)						
角度	$\pm 5^\circ$	公差	未注			
	$>30^\circ$					
	$>6\sim 30^\circ$					
	$\sim 6^\circ$					
变更单号	版本	日期	内容描述	变更	审核	批准





东莞市溪榜电子有限公司

DONG GUAN XI BANG ELECTRONICS CO., LTD

成品检验报告表

测量依据		工程图面		零件料号:				客户:									
图面版本		A版		零件名称:		XB-M19/2+3充电母座		客户名称:								1of1	
发行日期				材质规格:				客户料号:									
图面规格				检测结果							检测分析					备注	
				样品数目实测尺寸					Std.	中间值	% 公差		Acc/Rej		检测工具	供应商判定	客户判定
ITEM	NOMINAL	+TOL	-TOL	1#	2#	3#	4#	5#			上限	下限	上限	下限			
1	31.00	0.30	0.30	30.90	30.95	30.86	30.86	30.90	0.04	30.89	0%	47%			投影仪	OK	
2	29.00	0.20	0.20	28.92	28.95	28.96	28.95	28.96	0.02	28.95	0%	40%			投影仪	OK	
3	24.00	0.20	0.20	23.98	23.99	23.99	24.00	23.99	0.01	23.99	0%	10%			投影仪	OK	
4	19.00	0.20	0.20	18.98	18.99	18.99	19.00	18.99	0.01	18.99	0%	10%			投影仪	OK	
5	23.00	0.10	0.10	23.05	23.05	23.02	23.04	23.05	0.01	23.04	50%	0%			投影仪	OK	
6	3.20	0.10	0.10	3.19	3.20	3.18	3.19	3.20	0.01	3.19	0%	20%			投影仪	OK	
7	3.90	0.10	0.10	3.90	3.91	3.89	3.89	3.90	0.01	3.90	10%	15%			投影仪	OK	
8	2.30	0.10	0.10	2.29	2.30	2.28	2.30	2.29	0.01	2.29	0%	20%			投影仪	OK	
9	1.30	0.10	0.10	1.30	1.29	1.30	1.28	1.30	0.01	1.29	0%	20%			投影仪	OK	
10	24.50	0.20	0.20	24.45	24.44	24.45	24.46	24.45	0.01	24.45	0%	30%			投影仪	OK	
11	7.50	0.20	0.20	7.43	7.45	7.43	7.43	7.45	0.01	7.44	0%	35%			投影仪	OK	
12	3.90	0.10	0.10	3.90	3.92	3.93	3.92	3.90	0.01	3.92	30%	0%			投影仪	OK	
13	8.10	0.20	0.20	8.02	8.03	8.03	8.02	8.03	0.01	8.03	0%	40%			投影仪	OK	
14	4.30	0.10	0.10	4.32	4.28	4.30	4.31	4.30	0.02	4.30	20%	20%			投影仪	OK	
15	20.00	0.20	0.20	20.05	20.05	20.05	20.00	20.05	0.03	20.04	25%	0%			投影仪	OK	
16	17.00	0.20	0.20	17.00	16.99	16.98	16.99	16.99	0.01	16.99	0%	10%			投影仪	OK	
外观	序号	技术要求									检查方式/器具		检查频次/数量		供应商判定	客户判定	
	1	注塑表面无毛刺、飞边、缩水、断裂、压伤、注塑不全									目视		5PCS		OK		
	2	PIN针无变形、缺少、装配不到位、长短不一致、氧化									目视		5PCS		OK		
	3	基座无刮伤、飞边、裂纹、缺料、污损、色差									目视		5PCS		OK		
	4	电镀表面色泽均匀，无脱落、起皮									目视		5PCS		OK		
5	外形结构符合图纸、样件，无变形，所有零件装配到位，无错装、漏装、装									目视		5PCS		OK			
功能/性能	1	沾锡测试：端子前端基准面0.2mm处浸入260±5℃的锡槽中；历时2±0.5秒，端子吃锡95%以上。									高温锡炉		5PCS		OK		
	2	盐雾试验：72小时，无氧化现象。									盐雾试验机		5PCS		OK		
	3																
其它	1	包装：标签内容与产品相符，外包装箱整洁无损坏，要求包材完好正确，不可混料、多料或缺料、包装不可对物料品质有影响									目测		100%		OK		

最终判定: 合格 不合格

备注



东莞市溪榜电子有限公司

SPECIFICATION 规格书

Model Type:
类型型号:

XB-M19菱形母座2+3

1. Scope/适用范围

This specification is applies to jack connector which is used in Socket connector of charging trolley

本规格书适用于充电电车的插座连接器。

2. Rated / 额定值

2-1. Practical temperature range: -25°C to $+70^{\circ}\text{C}$

适用温度范围: -25°C to $+70^{\circ}\text{C}$

Humidity range: 90% RH. MAX. ($+40^{\circ}\text{C}$)

湿度范围: 90% RH. MAX. ($+40^{\circ}\text{C}$)

2-2. Preservation temperature range: -10°C to $+40^{\circ}\text{C}$

保存温度范围: -10°C 至 $+40^{\circ}\text{C}$

Humidity range: 85% RH. MAX.

湿度范围: 85% RH. MAX.

2-3. Rated voltage and current (MAX.): 300V DC , 30A

最大额定电压和额定电流: 300V DC , 30A

2-4. Appearance : No scratches、soil、rust or discoloration on the surface.

外观: 表面无划伤、脏污、生锈或变色等现象。

3. Construction / 说明

3-1. Outline And Dimension / 外观和尺寸

The appearance and dimensions of the socket should match the attachment drawing.

插座的外观和尺寸应与附件图纸相符。

3-2. Part And Material 部件和材料

Parts and materials should be consistent with the material list specifications.

部件和材料应与材料清单规格一致。

4. Electrical efficiency / 电气特性

Item 项目	Property 特性	Test condition 测试条件	Performance 判定
4-1	Withstand Voltage 耐电压	Withstand AC2000V (50Hz RMS) between two non-contact terminals for 1 minute 在两个不接触的端子之间, 能承受交流2000V (50Hz RMS) 并持续1分钟。	No dielectric breakd own shall occur. 无击穿现象发生
4-2	Insulation Resistance 绝缘阻抗	Using a 500volts DC insulation resistance meter between mutually insulated terminals or metallic parts 在相互绝缘的端子、端子与外壳之间, 插座应能承受施加的500V直流电压	100 M Ω Min. 最小100 兆欧



东莞市溪榜电子有限公司

SPECIFICATION 规格书

Model Type:
类型型号:

XB-M19菱形母座2+3

Item 项	Property 特性	Test condition 测试条件	Performance 判定
4-3	Contact Resistance 接触阻抗	Take a pair of matched terminals and measure the tail end of each terminal (voltage maximum 20mV, current maximum 100mA) 取一对匹配好的端子，测量各端子的尾端点 (电压最大 20mV，电流最大 100mA)。	10 mΩ MAX. 最大10毫欧

5. Mechanical Performance 机械特性

Item 项目	Property 特性	Test condition 测试条件	Performance 判定
5-1	Insertion and Extraction Force 插入力&拔出力	Plug and unplug with a matching plug at a frequency of 20-30 times per minute. 用相匹配的插头以每分钟 20-30 次的频率均速插头进行插拔。	20N (About 2kgf) to 60N (About 6kgf) 20N(大约 2kgf)至 60N(大约 6kgf)
5-2	Terminal retention 端子保持力	Counter the measured terminal directly with a dynamometer. The terminal shall not fall off after reaching the specified retention force 用测力计直接顶在被测端子，端子在达到规定的保持力后不得脱落	The retention force of signal terminal in plastic is greater than 20N, The retention force of the charging terminal in the plastic is greater than 60N, 信号端子在塑胶中的保持力大于 20N, 充电端子在塑胶中的保持力大于 60N

6. Durability / 耐久性能

Item 项目	Property 特性	Test condition 测试条件	Performance 判定
6-1	Life test 寿命试验	Under the condition of no load, plug and unplug with a matching plug for 3000 times in total, at a frequency of 20-30 times per minute. 在没有负载的条件下，以每分钟20-30次的频率，均速，用相匹配的插头进行插拔3000次。	The jack shall be comply with paragraphs 5-1 Insulation Conta resistance: less than 20mΩ 能满足项目 5-1 接触电阻：最大 20 毫欧



东莞市溪榜电子有限公司

SPECIFICATION 规格书

Model Type:
类型型号:

XB-M19菱形母座2+3

7. Solderability / 焊锡试验

Item 项目	Property 特性	Test condition 测试条件	Performance 判定
7-1	Resistance to soldering heat 耐焊性	The jack terminal should be dipped in solder under the condition as specified below: Temperature of solder: $260 \pm 3^{\circ}\text{C}$. Dip time: 5 ± 1 seconds. 端子浸入锡炉里, 按以下条件测试: 焊锡温度: $260^{\circ}\text{C} \pm 3^{\circ}\text{C}$. 浸入时间: 5 ± 1 秒.	After the test, the plastic base should not be deformed and the terminals should not fall off the plastic base. 试验后塑胶基座不应变形, 端子不从塑胶基座上脱落下来
7-2	Solderability 可焊性	Temperature of solder: $245 \pm 3^{\circ}\text{C}$. Time of dip: 3 ± 0.5 seconds. 焊锡温度: $245 \pm 3^{\circ}\text{C}$. 浸入时间: 3 ± 0.5 秒	Coating of solder area should be more than 95% 焊锡面积要求达到95%以上

8. Environment test / 环境试验

Item 项目	Property 特性	Test condition 测试条件	Performance 判定
8-1	Cold test 低温测试	Place the housing for 96 hours at a low temperature of $-25 \pm 3^{\circ}\text{C}$. Then, place it under standard atmospheric conditions for 1 hour and test. 在 $-25 \pm 3^{\circ}\text{C}$ 低温条件下将基座放置96小时, 再在标准大气条件下放置1小时, 然后再测试。	No obvious change in appearance Contact resistance: $20\text{ m}\Omega$ max. Insulation resistance: $100\text{ M}\Omega$ min. Withstand voltage: AC 2000V.
8-2	Heat test 高温测试	The housing should be stored at a temperature of $85 \pm 2^{\circ}\text{C}$ for 96 hours. Then it should be subjected to standard atmospheric conditions for 1 hour and test 在 $85 \pm 2^{\circ}\text{C}$ 高温条件下将基座放置96小时, 再在标准大气条件下放置1小时, 然后再测试。	外观没有明显的改变。 接触电阻: 小于 20 毫欧。 绝缘阻抗: 大于 100 兆欧。 耐电压: AC 2000V.



东莞市溪榜电子有限公司

SPECIFICATION 规格书

Model Type: 类型型号:	XB-M19菱形母座2+3
-----------------------------	----------------------

Item 项目	Property 特性	Test condition 测试条件	Performance 判定
8-3	Humidity test 耐湿试验	<p>The housing should be stored at a temperature of $40 \pm 3^{\circ}\text{C}$ with relative humidity of 90% ~ 95% for 96 h. Then it should be subjected to standard atmospheric conditions for 1 hour and test</p> <p>在温度为 $40 \pm 3^{\circ}\text{C}$，相对湿度为 90%~95% 条件下，将基座放置 96 小时，再在标准大气条件下放置 1 小时，然后再测试。</p>	<p>No obvious change in appearance Contact resistance: $40\text{m}\Omega$ max. Insulation resistance: $100\text{M}\Omega$ min. Withstand voltage: AC 2000V. 外观没有明显的改变。 接触电阻: 小于 40 毫欧。 绝缘阻抗: 大于 100 兆欧。 耐电压: AC 2000V。</p>
8-4	Temperature Cycling 温度循环	<p>Place the Jack under the conditions shown below and then place it in the stand at room temperature for 30 minutes.</p> <p>将插座放置于如下所示条件下进行试验, 然后在室温条件下放置 30 分钟。</p> <div style="text-align: center;"> <p>(TEMPERATURE) 温度</p> <p>(five cycles) (5次)</p> <p>(TIME) 时间</p> </div>	
8-5	Temperature rise test 温升试验	<p>Connect the specified current to the charging terminal and measure the number of terminal temperature rise after the terminal temperature is stable</p> <p>充电端子接通规定的电流，等待端子温度稳定后，测量端子温度上升的数则</p>	<p>The temperature rise shall not exceed 50°C 温度上升不超过 50 摄氏度</p>



东莞市溪榜电子有限公司

SPECIFICATION 规格书

Model Type: 类型型号:		XB-M19菱形母座2+3	
Item 项目	Property 特性	Test condition 测试条件	Performance 判定
8-6	Salt spray test 盐雾测试	Temperature: 35 ± 2°C Solution: 5 ± 1% Spray time: 72hours Wash and dry it at room temperature after the experiment. 温度35±2°C 盐水浓度 5±1% 盐雾时间72小时。实验后常温水洗，室温干燥。	No obvious rust in the appearance. 外观没有明显的生锈现象。

9. Test condition / 测试条件

Unless otherwise specified, the test and measurement temperature is between 15 ° C and 35 ° C, the relative humidity is between 25% and 85%, and the atmospheric pressure is between 86 kPa and 106 kPa.

However, when any doubts arise on the judgment value under the above condition, the test and measurement are carried out at 20±1 ° C, the relative humidity is 63% to 67%, and the air pressure is performed at 86 kPa to 106 kPa.

除非另有指定，否则测试和测量温度在 15° C~35° C，相对湿度在 25%~85%，气压在 86kPa~106kPa 条件下进行。

当在这个条件下判定出现疑问时，测试和测量在 20±1° C，相对湿度 63%~67%，气压在 86kPa~106kPa 条件下进行。

10. Amendment / 变更修正

When it is necessary to amend the specifications, it should be negotiated and agreed by the manufacturer and the customer before proceeding.

当有必要对规格书进行变更修正时，应该在制造商和客户共同商议及同意后才可以进行。



东莞市溪榜电子有限公司

DONG GUAN XI BANG ELECTRONICS CO., LTD

产品（全性能）检验记录表

产品规格型号		XB-M19菱形母座2+3		数量		5 只		检验日期		2023.4.16	
检验项目	技术要求	检验结果									
		1	2	3	4	5	6	7	8	判定	
1、外观	塑料件表面光洁,无明显缩痕、变形、毛刺、飞边、缺料、杂色等。	√	√	√	√	√					OK
	引脚针镀层无脱皮、露底、发黑、发黄等现象,表面光洁,无毛刺、弯曲等。	√	√	√	√	√					OK
2、结构尺寸	A: 29	29.05	28.95	28.98	28.98	29.03					OK
	B: 31	30.98	31.02	30.93	30.96	30.95					OK
	C: 24.5	24.43	24.55	24.46	24.48	24.52					OK
	D: $\phi 23 \pm 0.1$	23.05	22.98	23.06	23.07	23.03					OK
	E:										
	F:										
3、互换性	同一型号/规格的公头应能通用互换	√	√	√	√	√					OK
4、接触电阻	寿命前 $\leq 10 m\Omega$	5	4	6	5	3					OK
5、接触电阻	寿命后 $\leq 50 m\Omega$	12	8	10	15	12					OK
6、耐压	在相互绝缘的接触脚之间,插座能承受2000V电压(AC, 1mA、50/60Hz RMS) 并持续1分钟	√	√	√	√	√					OK
7、绝缘电阻	在相互绝缘的端子、端子与外壳之间,插座应能承受施加的500V直流电压。 $\geq 1000M\Omega$	√	√	√	√	√					
8、保持力 (插拔力)	单Pin正负极针的保持力 $\geq 70N$,其它信号针 $\geq 20N$ 。	√	√	√	√	√					
	用公头对母座进行对插拔力: 20-60N	√	√	√	√	√					
9、可焊性	焊锡温度: $245 \pm 3^\circ C$. 浸入时间: 3 ± 0.5 秒 浸入深度: 2.5 mm(从端子顶部开始). 焊锡面积要求达到95%以上	√	√								
10、高低温循环测试	-25°C/2H~+70°C/2H 周期循环 18次 接触电阻 $\leq 0.01\Omega$, 绝缘电阻 $\geq 100 M\Omega$	√	√	√	√	√					
11、高温循环试验	将插座放置在 $70 \pm 2^\circ C$ 高温条件下持续96小时,然后在室温条件下静置30分钟。 绝缘电阻: 最小 $100 M\Omega$ 接触电阻: 最大 $30 m\Omega$	√	√	√	√	√					

12、低温实验	将插座放置在-25±5℃低温条件下持续96小时，然后在室温条件下静置30分钟。 绝缘电阻：最小100 MΩ 接触电阻：最大30 mΩ 塑胶壳体无破裂。	√	√	√	√	√				
13、振动试验	在振动试验台上的产品带电应承受振幅3mm、振动频率22HZ，在前后、左右、上下各振动10min，应不许有接触不良现象。	√	√	√	√	√				
14、寿命测试	在没有负载的条件下，以每分钟20-30次的频率，均速，用相匹配的公头进行插拔3000次： 绝缘电阻：最小1000 MΩ 接触电阻：≤30 mΩ	√	√	√	√	√				
16、盐雾试验	在温度为35±2℃条件下，盐水浓度为5±1% 测试时间：72±0.5小时 表面无发黑、露铜。 绝缘电阻：最小1000 MΩ 接触电阻：最大30 mΩ	√	√	√	√	√				
注：本表依《产品规格书》 实施检验并记录		检验结论：合格								
		检验员：腾慧敏					审核：赖海杰			